



The THUMB PRINT
Thermal Thumbers Of Metro Atlanta

www.thermalthumbers.com
David Mills Editor
 (404) 509-4209
 davidmillsatl@gmail.com





Jan.-Feb., 2018

HEADS UP

Welcome to the first issue of the year. It's time for all of us to get set up for 2018. Hopefully, we're grinding away in the middle of a building binge. Good luck with that! As for your editor, I wouldn't call it a binge, but progress is being made on several projects. (May I not be alone in this regard!) A full report on the annual banquet follows, along with a lovely photo collage by David Barfield. A few pages hence, you'll find the contest schedule, so mark your calendars thusly. Please note the indoor dates after May could shift because not all have final approval by St. Lukes. This uncertainty will be cleared up shortly. Several Thumbs have been active, and several news nuggets follow, an example being set for all of us. A report follows of the annual banquet and the last three indoor contests. A pointed nag for club dues renewal follows immediately, so do the right thing as directed. Don't forget about the Southeast Model Show in Perry March 3 and 4. Be there, or be square.

Time for me to get out of the way. Later, y'all.

RENEWAL NAG

OK, it's time to fish or cut bait. Club dues are due. Ain't no more fooling around. You know who you are. Fill out the membership form that follows and stroke that check, signed on the line that is dotted, and mail it to Karl "Karats" Hube at the address indicated. Eyes on you!

Be aware of the good news Karl brought to the annual banquet. Basically, the membership is holding strong with well over forty souls. He suspects we might even see a modest increase in 2018 from last year. Good for us! Be a part of it by sending Karl that check.

THUMBS IN PRINT

Josh Finn has a good piece in the Nov., 2017 issue of the NFFS digest. It's part of a good presentation of the "Hep Cat", a very well known and revered example of the British Lightweights. It was designed and built by John Barker in 1944 (not our expat John Barker) and published shortly thereafter in *Aeromodeller*. It's eligible for use in SAM's Old Timer Rubber, FAC's Old Time Rubber Fuselage and NFFS's NosRub events. A three-fer and oft-built and flown, you can't go wrong with this one. The well illustrated article presents much sound advice from John and Josh. Plans are available from a number of sources, but a modern version by John from 2004 can be had from the NFFS Plan Service. Get yours today!

THUMBS DRESSED UP

Our second visit to *Petite Violettes* for our annual banquet didn't disappoint. The weather didn't cooperate, but the cold drizzle didn't deter any attendees as far as we could tell. We were only down a few attendees from last year, a good ration of 28 Thumbs and spouses, mistresses and life partners. They put us in the back banquet room this time, really a smaller and much better venue for us. The entrees got rave reviews all around. At this

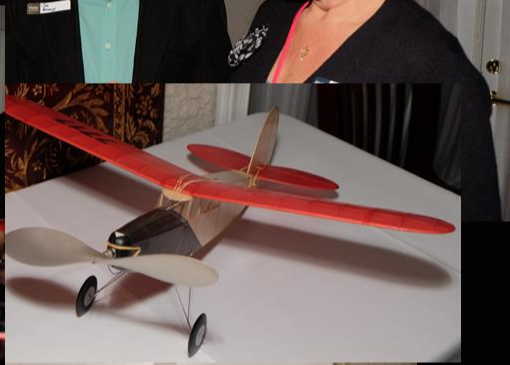

early juncture this writer sees no reason not to return. The raffle was another success; everybody took home some goodies. Thanks go to Dohrman Crawford and Jim Altenbern for all these arrangements.

The awards ceremony featured the usual parade of our competition *glitterati*. The club's high point tourney was contested by 24 Thumbs, well over half of our membership of 42 stout-hearted souls. Congrats to us! Karl Hube escorted the George Perryman Perpetual Award home with an august score of 56 points. Closing in quick succession were Hope Finn (49), Dohrman (48) and Josh Finn (45). It's worth noting that the next score below the top four was 26, indicating a wide gap between the aforementioned four thereby festooned with glory and the lumpen remainder. The Bob Baker Old Timer award was bestowed upon Hope for her expert employment of the Comet "Phantom Flash". Doubling down, Hope took home the Model of the Year Award with the same device. Dohrman took home the scale high point award with a dominating score of 24 points. Likewise, Dohrman won the SCat Jet High Point Award with the same dominance. The club's high point trophy has all the flash, but the Norm Purdy Service Award has all the depth. This year Jim took it home for his multitude of good works on our behalf in 2017. Thanks from us all, Jim. Our Show-and-Tell exhibit furnished an eyeful of goodies. Quite a few new models were showcased. Reports from many attendees indicate many more are on the way, which was good to hear. Spring should be fun!

Looking back at 2017, we had a great year. No reason to think we can do the same in 2018. So, glue some sticks together and show up somewhere!

THUMBS AT THE EASEL

Dohrman Crawford passes along the following bit of artwork he recently completed. He got a bug to paint something, and this portrayal of Dave Stott's "Pugnacious Pursuit" was the result. Frankly, I like it. Having seen a bit of folk art in my time, this is good stuff. Who knew?! (Not bad for a hoopy!)



THUMBS IN BIDNESS

Josh Finn is at it again. He brought a number of new kits and other offerings to the banquet. Also, for your further information he provides the following:

"We've got a full line of goodies at jhaerospace.com. These include a series of rocket-boosted models (swing wing and fixed wing) and an R/C micro DLG. Also, there are four catapult gliders:

1. "Aleda" is a beginner's catapult glider. Builds really fast with self-keying surfaces. I've built several with the edges just rounded off--no airfoil, and they do a good 30-40 seconds in dead air.
2. "Carbonette 8" is my 8-inch catapult/hand launch model based off the Sweepette. These do a good 70 seconds in dead air when trimmed correctly. Basswood leading edge reinforcement is included. I've been campaigning this design for almost 10 years.

3. "Carbonette 6" is the 8-inch clipped down for the 6 inch postal contests. They'll reliably do over a minute in dead air when trimmed out.
4. "Carbonette 12" is a 12-inch, Cat III-IV standard catapult glider/calm weather outdoor model. I say calm weather only because it doesn't have a DT (yet). Mine does 80-plus seconds in dead air. Pretty easy to build, nice and stable. A definite contender for the "Beat the Vartanian" event at the Nats. Launches very high.

"All the catapult gliders include a catapult handle and Tan Super Sport rubber, full size plans/templates, laser-cut parts, and link to a full length build video. All of the "Carbonette" series use a forward grip and drooped nose for maximum pull length and minimal fatiguing of the tail boom. The "Aleda" uses a standard stinger grip and a beefy fuselage to handle the stresses."

Also, be aware Josh has acquired the bulk of the Jim Walston's models and has big plans for them. He's establishing a model museum of sorts, something of a homage to departed Free Flight modelers. Beyond this, he's looking for homes for many of them. He might have things sorted out to a degree by spring. I'd contact him then if you're looking for some old flying iron or a keepsake.

2018 CONTEST SCHEDULE

This just in from Dohrman Crawford: "It has taken a while to iron out some scheduling kinks, but this should work as a schedule. As always, remember we have no approval at St Luke's yet for dates after May, so the dates here are just guesses. There will certainly be some changes indoors. Outdoors should work fine. Contest Directors, let me know right away if you cannot be there on these dates. Questions or comments, you know where to find me."

- March 2-3: Southeast Model Show, Perry, GA
- March 10: St Luke's, CD-Dohrman Crawford
- March 17-23: F1D World Championship, West Baden, Indiana
- April 7: St Luke's, CD-Lee Russell
- April 22: NGT sod farm, April Fools, CD-Karl Hube
- May 12: St Luke's, CD-Nick Ray
- May 19-20: Kudzu Meet, North Carolina, info Jimmy Jordan at jjordan18@ec.rr.com
- May 23-28: USIC Indoor Nats, Rantoul, IL
- May 27: NGT sod farm, May Daze, CD-Dohrman Crawford
- June 9-10: NGT sod farm, Chattahoochie Challenge FAC, CDs-Jim Altenbern/Gary Morton
- June 21-25: Kibbie Dome. Moscow, Washington
- June 23: St Luke's, CD-Joshua Finn
- July 14: St Luke's, CD-Bill Gowen
- July 15: NGT sod farm, Peach State Champs, CD-David Mills
- July 18-21: FAC Nats, Geneseo, NY
- July 23-27: USOC Outdoor Nats, Muncie Nats
- Aug. 12: NGT sod farm, Fizzle While You Sizzle, CD-Graham Selick
- Aug. 18: St Luke's, CD-Nick Ray
- Sept. 15: St Luke's, CD- Joshua Finn
- Sept. 23: NGT sod farm, Summers Swan Song, CD-David Barfield
- Sept. 27-28: FAC Outdoor Nats, Muncie, IN
- Oct. 7: NGT sod farm, Last Fling til Spring. CD-Lee Russell
- Oct. 20: St Luke's, CD-Bill Gowen
- Nov. 4: NGT sod farm, Turkey Shoot, CD-Gary Baughman
- Nov. 17: St Luke's, CD-Nick Ray
- Dec. 8: St Luke's, CD-Joshua Finn
- Jan. 12, 2019: St. Luke's, CD-Bill Gowen

TREASURE TROVE

We benefit from a few selections this time from Josh Finn. I wasn't very active in same due to some work out-of-town, so his timing was perfect. He forwarded a number of interesting designs based on his excursions into Free Flight outer realms, in this case, the forties and fifties from Europe and the old USSR. The first is an ideal candidate for FAC's Two Bit Plus One category, the "Spin 42", an obscure 1942 offering from Scandinavia by Josh's reckoning. (Unfortunately, the wing is a bit small for serious consideration in the SAM's Small Rubber ranks.) Perusal indicates much of worth. The wingspan is spot-on at 24.8 inches (630 mm) and provides an ideally sized prop of 10.125 inches. Lightly drawn throughout, it certainly carries less lumber aloft than its peers. The moments and areas leave nothing in doubt, and the flat-bottom airfoils oblige. This bird will fly and look good doing it.

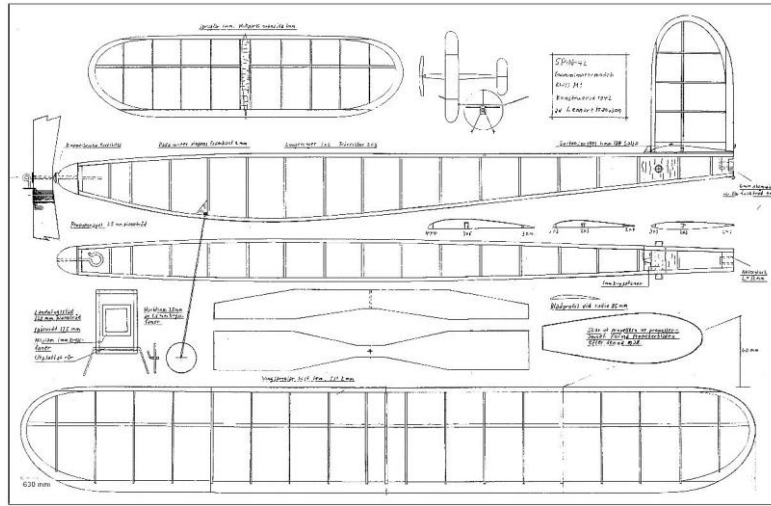

Next in line are two French Coupes from 1944 that could slide, variously with less or more effort, into SAM's Rubber or NFFS's NosRub categories. (Unfortunately, the two wingspans are a few inches over the 36-inch wingspan limit, so no FAC slots.) The first, "Mattern's 1944 Winner" (according to my eight grade French) deserves a look because its fundamentals do tempt. For starters, the Eiffel 400 airfoil is well-traveled and won't fail you. The wing's area is a bit in doubt; as its flat area is over both 150 squinch limits. But, the ample dihedral might decrease the projected area enough. The overall lines are sleek and sexy, and foreshadow future design trends. Also, the twin fins allure. The one-bladed prop needn't deter the flight line veteran. This bird will fly and look good doing it.

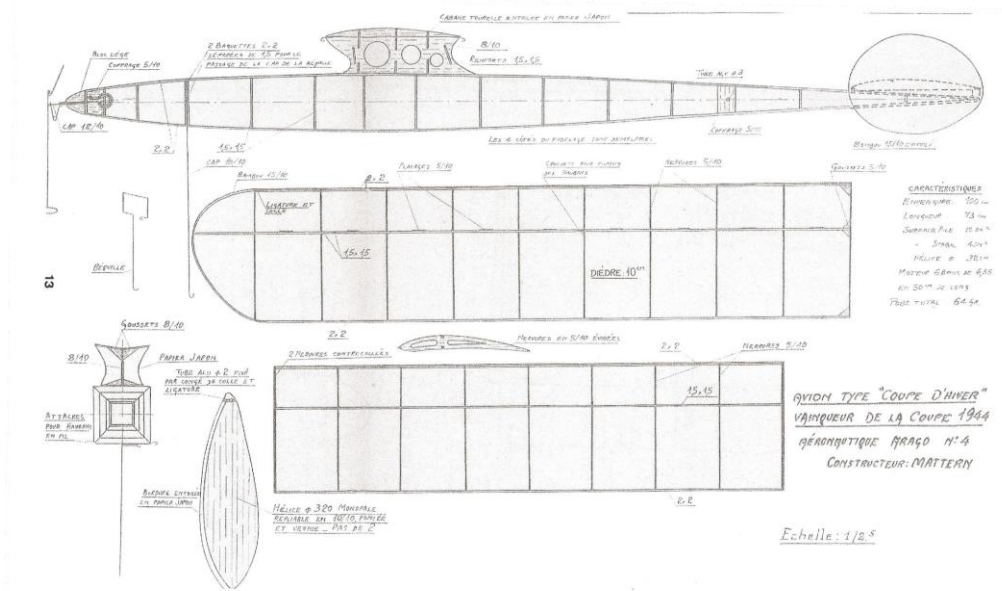

Coupe-Mattern's 1944 Winner

The second Coupe, “De Jaeger’s 1944 Winner”, like its *compagnon soldat*, is intriguing for many of the same reasons. Unlike the “Mattern”, however, this one clearly presents cabin-esque profile and looks good in that context. Drawn lightly, minimal construction is featured throughout. Its wing’s projected area is well under the 150 sqinch limit, and the Eiffel 400 airfoil will, again, serve well. The one-bladed prop of 25 inch actual radius should churn well. The flat plate stab is bothersome to modern eyes, but not to worry, with a forward CG it’ll work well enough. The bird will fly and look good doing it.

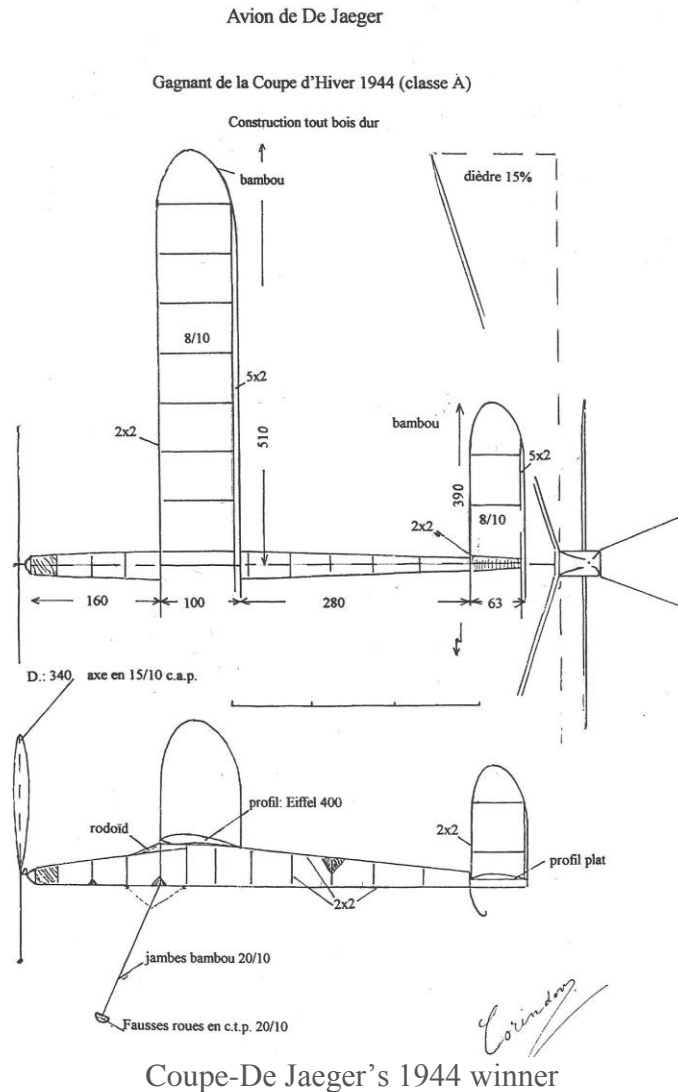

CARRY-ONS

A good percentage of the world’s premier F1D fliers were in attendance at St. Lukes this past January, on hand to practice for the upcoming World F1D Champions this March in West Baden, IN. Naturally, there was plenty of great flying and other eye candy to see. (If you want a closer look at Brett’s F1D, it’s featured in the Nov.-Dec., 2017 issue of the NFFS digest. It’s a lovely model, well built and flown.)

After a bit of this display of excellence, I realized that a lot of very high end carry-on luggage was assembled, too. Pictures were taken, and those follow, in order: Nick Ray, Josh Finn, John Kagan and Brett Sanborn. Needless to say, the overall workmanship was amazing, and this efficient space usage should inspire a lot of us outdoor fliers. Somehow, our homespun flight boxes made of cardboard with like partitions don’t look quite so slick anymore.

Frankly, you’d have to go to a big regional or national contest to see a better collection of F1D flying iron, partly a testament to the appeal of our humble flying site at St. Lukes, “where records go to die”. Let’s all never forget what a blessing this facility is for the club.



THE FINAL RECKONING

Here's how the 2017 high point totals ran. A resounding story is told therein. We flew a lot last year, and we shouldn't defer from doing the same in 2018. Let the roll be called. Gird your loins, lads, for the game's afoot.

Karl Hube	56	Bill Gowen	16	Savannah Canady	9
Hope Finn	49	Jim Conery	16	Doug Demasie	7
Dohrman Crawford	48	Dan Crews	14	Gary Baughman	6
Josh Finn	45	Lee Russell	14	Graham Selick	5
Richard Schneider	26	David Barfield	12	Joe Ryan	5
Gary Morton	23	Jimmy Jordan	11	Matt Canady	4
Frank Perkins	22	Jim Altenbern	10	James Martin	3
Nick Ray	21	David Mills	9	Hayden Ashworth	1

COMMUNION NAG

We mentioned the Southeast Model Show in Perry this March 2 and 3 in the last issue, and we hereby nag as a reminder. Simply put, it's the best place on earth to be if you're a model airplane nut. The flyer was published in the last issue. No excuses, eyes on you!

NEXT ISSUE

Look for the next issue in April. It'll carry a report on the Perry show and the indoor contests in the interim. Dohrman is still slogging away with the AMA for all contest sanctions, and final illumination should be forthcoming from the good people at St. Lukes. Ergo, we should have further firmness in the overall 2018 contest schedule. Expect a serious pimping of the outdoor season. As always, send me your articulated, photos, plans, rants and raves. Don't make me work too hard! Later, y'all.

December Indoor Contest Report

Six fliers registered for the Dec. 16 at St. Lukes contest and recorded 24 official flights. Here are the complete flight times, Bill Gowen, CD, reporting:

Limited Pennyplane

Dan Crews 6:03
Karl Hube 6:01

Ministick

Nick Ray 5:22
Lee Russell 3:04

Dime Scale

Richard Schneider 2:02, total of 3

No-Cal Scale

Richard Schneider 4:45, total of 3
Karl Hube 3:00, total of 3

Peanut Scale

Richard Schneider 0:45

Hangar Rat

Karl Hube 3:11, best 2

January Indoor Contest Report

Nine fliers registered for the Jan. 13 contest at St. Lukes and recorded 45 official flights. Here are the complete flight times, Bill Gowen, CD, reporting:

F1D

Brett Sanborn 20:57
Lee Russell 7:08

Limited Pennyplane

Dan Crews 5:32

Ministick

Nick Ray 9:10
Joshua Finn 8:42
Hope Finn 6:11
Lee Russell 3:07

F1R

Joshua Finn 27:22

Phantom Flash

Hope Finn 5:54, best 3
Joshua Finn 5:51, best 3
Dan Crews 4:06, best 3

Hangar Rat

Dohrman Crawford 5:27, best 2
Joshua Finn 2:25, best 2
Hope Finn 1:33

Wright Stuff MS

Bill Gowen 3:00





February Indoor Contest Report

We had a great turnout for the February indoor contest, probably one of the largest I have seen in my two years of attending contests at St. Lukes. Jim Conery made his debut with his Easy B and an ornithopter. Current FAI F1D World Champion Kang Lee was there as well as a guest of Bill Gowen. All together we had twelve sign in for the event. Nick Ray and I (mostly Nick) have schemed up a monthly award/trophy system, the Order of the Rainbow Unicorn. The awards are to be returned each month to be given away again. We are hoping this will inspire more return flyers. (Nick will explain the winners and the process later in the newsletter.)

Here are the results, Lee Russell, CD, reporting:

Hand Launched Stick

Josh Finn 31:48

Dime Scale

Richard Schneider 43+:43+40 = 129

No-Cal Scale

Karl Hube 69+75 = 149

Richard Schneider 55+67+67 = 189

Peanut Scale

Richard Schneider 41+39+28 = 108

Dohrm Crawford 38+51+51 = 140

Ministick

Nick Ray 8:55

Josh Finn 8:25

Hope Finn 6:34

F1R 35 CM

Josh Finn 23:10

Pennyplane

Dan Crews 11:35

F1D

Josh Finn 18:47

Hangar Rat

Dohrm Crawford 175+181+191 = 547

Phantom Flash

Hope Finn 108+112+143 = 363

Dan Crews 69+99 = 168



The Order of the Rainbow Unicorn

Unicorns are awarded for 1st through 4th place based on the percentage of the club records attained on the day of the contest (or the national record if it was set at St. Luke’s). The goal is to allow modelers who fly different classes to indirectly compete with one another. If a modeler would win more than one unicorn based on his/her performance in multiple events, only the highest performance is scored. The unicorns are to be returned the following month to be redistributed based on that month’s contest standings. (Sounds a little “festive” to me.—DM.)



The winners of the first contest are:

Dohrman Crawford - Hangar Rat
3:11+3:01 = 6:12 @ 6.03 = 102%
Joshua Finn – Hand Launched Stick
31:48 @ 34:24 = 92%
Nick Ray – Ministick
8:55 @ 10:01 = 89%
Hope Finn – Phantom Flash
6:03 @ 8:29 = 72%

2018 TTOMA MEMBERSHIP FORM

Name _____ AMA # _____

Address _____

State and Zip Code _____ Other Family Members and AMA # _____

Telephone _____ E-mail _____

**\$20.00/yr. adults, plus \$1.00/yr. for all juniors and for additional family members in same household.
Send check, payable to TTOMA, to Karl “Karats” Hube/104 Smith Forest Lane/ Alpharetta, GA
30004/770-886-0604.**
