

**The THUMB PRINT**  
**Thermal Thumbers Of Metro Atlanta**

www.thermalthumbers.com  
**David Mills Editor**  
 (404) 509-4209  
 davidmillsatl@gmail.com

AMA Charter # 1834  
 FLYING ACES club  
 SAM  
 NYFS

## March-April, 2015

### HEADS UP

Welcome to the second issue of the year. The club is off to a roaring start, and we've the first few contests reports of the year for your enjoyment. Happily, my repeated calls for contributions from the membership brought bountiful fruit this time, and they follow. Actually, more was forwarded for these pages that can be published! Ergo, we'll see more in the next issue. Keep them coming, y'all.

For those of you who haven't heard, I'm very happy to announce the birth of Caleb Joshua Finn to Hope and Josh. Congrats to both!

Time for me to get out of the way. Glue some sticks together and show up somewhere!

### RENEWALS

Get ready for a two-pronged nag. First, there're quite a few of you who haven't renewed your club membership. Ergo, at the very least, this will be the last copy of the newsletter until you've re-upped. More importantly, you won't be one of us anymore. Go look in the mirror and ask yourself what's the right thing to do. You know who you are. Send Karl "Karats" Hube that check. The membership form follows.

Later on in this issue I'll begin an on-going harangue about joining of the National Free Flight Society. Thankfully, the club is already well represented; approximately two-thirds of the membership already belongs. But, we can increase this percentage further. Note the one-half-off offer is still in effect for first-timers and one-time members who've gone off the reservation for a few years. The signup form follows. Get on it!

### THINGS TO DO, PLACES TO GO AND PEOPLE TO SEE

The indoor season is in full swing, and we just had our first outing at the sod farm. You can't say the club doesn't provide flying opportunities. You should all take advantage. Glue a few sticks together and show up somewhere!

May 16. Indoor. St Lukes. Nick Ray. CD

May 17. Outdoor. N GA Turf Farm. May Daze. Dohrman Crawford CD

June 8-12. USIC Nats. Colorado Springs, CO

June 20. Indoor. St Lukes. Bill Gowen CD

June 27. FAC Outdoor. N GA Turf Farm. FAC. Jim Altenbern. CD

June 28. Outdoor. N GA Turf Farm. June Bug Jamboree. David Barfield CD

July 12. Outdoor. N GA Turf Farm. Peach State Champs. Whit Russell CD

July 18. Indoor. St Lukes. Dohrman Crawford CD

July 27-31. USOC Nats in Muncie, Indiana

August 9. Outdoor. N GA Turf Farm. Pop Purdy's Contest. Graham Selick CD  
August 15. Indoor. St Lukes. Nick Ray CD  
Sept 5 (Sat.). Outdoor. N GA Turf Farm. David Barfield CD.  
Sept 19. Indoor. St Lukes. Bill Gowen CD  
October 4. Outdoor. N GA Turf Farm. CD David Mills CD  
October 10. Indoor. St Lukes. Nick Ray. CD  
November 8 (Sat.). Outdoor. N GA Turf Farm. Turkey Shoot. Gary Baughman CD  
November 21. Indoor. St Lukes. Bill Gowen CD  
December 12. Indoor. St Lukes. Nick Ray CD

### **THE FEW, THE PROUD, THE NFFS MEMBERS**

I checked the January, 2015 NFFS membership roster and can now proudly proclaim the following twenty-four Thumbs are members in good standing in the National Free Flight Society. My fellow Thumbs, if your name isn't listed below, you aren't. (If I've missed anyone out there, I apologize.) Over the summer, I'll be approaching the rest of you and offering you a chance to redress this sin of omission. I'll be bribing you with swag in the form of free issues of the NFFS digest, the best Free Flight magazine in the world. You'll also be reminded about the one-half-off offer for new members and back-slidden recalcitrants.

I look forward to publishing another list an issue or two hence with more Thumbs being counted among the few, the proud and the NFFS members. I'll also add there're a few NFFS members who haven't renewed their TTOMA memberships yet, so that conundrum needs to be addressed, too.

Jim Altenbern  
Gary Baughman  
Bill Brown  
James Conery  
Dohrman Crawford  
Brook Dixon, Sr.  
Randy Ficklen  
Bill Gowen  
Ed Hardin  
Karl Hube  
Jim Jennings, Sr.  
Jimmy Jordan

Dean McGinnis  
David Mills  
Gary Morton  
Al Pardue  
Frank Perkins  
Linda Raschke  
Whit Russell  
Joe Ryan  
Richard Schneider  
Graham Selick  
Rolf Svensson  
Bob Thoren

### **STILL IN BUSINESS**

Peck Polymers has found a new home. It's been purchased by Chuck Imbergarno of Connecticut. Chuck is an experienced Free Flighter, and he plans to continue the familiar product line, plus add new kits and accessories, so look for more orange boxes coming down the pike. The existing website will remain in effect, but give him a little while to get organized. Good luck to Chuck!

Campbell Custom Kits has a new owner, Retro RC of Michigan. I checked their website, and it's an intriguing mix of small Free Flight items and oddball RC stuff. Word is they plan to continue the kit production and sell the same merchandise. Basically, both companies appear to be in good hands—best of luck to them.

### **THUMBS IN PRINT—OOPS, MY BAD**

For whatever reason, your trusty editor didn't receive his May, 2014 issue of the NFFS digest in either the pulp or digital version. No clue as to how that happened. Search me. Usually, my mama's librarian/OCD gene kicks in, and I snap to and go looking for it but not this time.

Regardless, the Thumbs are featured prominently therein. First, Josh Finn's Small Mulvihill *Shortcut* is given a few hundred words and a lovely full color plan furnished. Second, Nick Ray's category 1, world record-breaking F1D (at the time anyway!) is given similar coverage. Readers may recall his setting of the world record last May within the cozy confines of St. Luke's Great Hall. Again, a few hundred well-chosen words are spilled and a lovely full page plan is provided, ably drafted by our own Bill Gowen. Both plans follow. Enjoy.

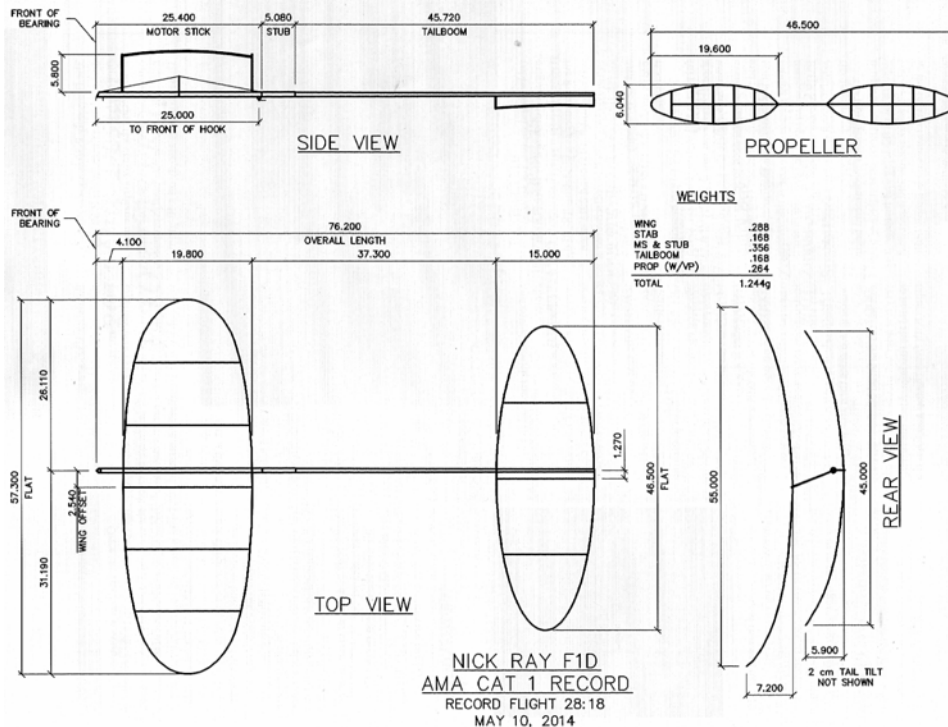
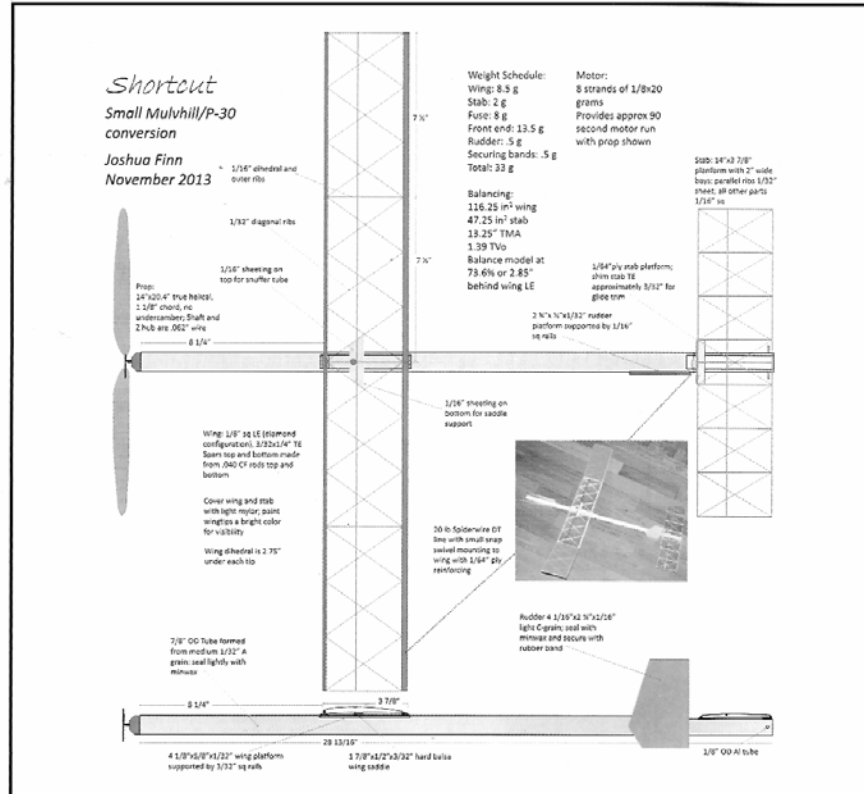

## SOUTHEAST MODEL SHOW

Your trusty editor wasn't able to go to Perry for the annual Gathering of the Tribes, but Hope and Josh Finn attended, and he and Hope kept very busy throughout the world's largest model aviation swap meet. Josh provides the following report:

"Hope and I had the privilege of being one of the organizers and key participants for the 2015 SMS. Having never attended before, we had no idea what to expect, and we ended up really enjoying ourselves, though we were completely exhausted by Saturday evening.

"More than 1000 vendors attended, and although the meet is overwhelmingly oriented toward RC, there was a significant amount of pure Free Flight equipment available, as well as engines and support systems useful to the Free Flighter. Ken Achee, Jim Lewis, and I made up the primary Free Flight presence. Ken sold off a bunch of excellent FF kits to excited buyers and collectors. In addition to tremendous demand for my swing-wing rocket, our indoor Free Flight activities generated considerable attention.

"SMS makes available an indoor flying site throughout the show. I was shocked at how little flying occurred on Friday, and much of the time, I had the air to myself. For those interested, you have to be willing to share the air, but most of the folks there are courteous to the Free Flight models and don't stir up the air that much. Additionally, you can sign up to be part of the noon demos, which will give you a few minutes of having the air completely to yourself. Hope and I managed to have three models in the air at once during our demo slots, and the audience just ate it up. When we walked back to the flight line, spectators surrounded us asking questions and taking down

information in hopes of trying indoor flying for themselves. If you want to get more Free Flight participation, show your stuff off at SMS. Many in the RC community are really interested in our craft. Flite Test's recent videos have really spurred interest in our little models.

"Lastly, I had the privilege of flying a \$900 Snipe DLG late the second day and managed to thermal it to speck-out altitude. Not bad for my one and only flight ever on a high-end RC sailplane! The altitude these guys are reaching on launch makes me ask a lot of questions about how we do Free Flight gliding. I picked up a nearly pristine DLG wing for \$20, and there were lots more available. The meet was worth it for that alone, as those suckers cost upwards of \$300 new."

Many thanks, Josh. Good job.



## BETWIXT AND BETWEEN

As covered previously here and elsewhere, SAM moved their Old Timer cutoff date up to Dec. 31, 1950 from the previous date of Dec. 31, 1942. The initiative passed by wide margins and opens up a large number of designs for use under the SAM banner.

(Editor's note: there was some moaning and groaning from the other side, as was expected. However, this position lacked much *gravitas*, to this writer as least, because SAM's original cutoff date of Dec. 31, 1942 was selected by the SAM founders just because it allowed the plans from this era to be reprinted anew without worry over copyright restrictions. The 1950 date was selected by the Brits and others for their Vintage and kin categories from the very offing and was based on real, pertinent FAI rules changes at the time—better law altogether.)

Early on, NFFS members and other fans of its Nostalgia era designs wondered what effect SAM's move would have on the flying of NFFS's Nostalgia designs from this time period. Well, Bob Mattes

has just released the current Nostalgia rulebook which clarifies the situation. Basically, there'll be no changes in the Nostalgia era time brackets, meaning the overlap between SAM Old Timer and NFFS Nostalgia designs will go on happily without fanfare. In other words, designs from this overlapping time period can be flown in both sets of events and can be considered two-fers. For example, you can fly your *Wanderer* and *Senator* in both SAM and NFFS events. One can either consider this a problem or a convenience. I choose the latter.

### **YIKES!!**

This following photo is taken from the pages of the latest *Sticks and Tissue*, the delightful rag from John Parry in Great Britain. What can you say? These two single (or soon-to-be divorced) guys must have a lot of time and money on the hands and one heck of a basement. I assume the model is from the other side of the pond, as this beast would easily exceed the AMA's weight limits. I also assume it's a RC model because CL would require superhuman strength and FF would require, well, insanity. Duck and cover!



### **LATEST NEWS FROM THELMA**

It was good to see Thelma at the annual banquet. I spoke to her since then, and she's moved to a senior's living facility in Peachtree City, and they're putting the Hodson place up for sale. Without Frank around to keep it up, it's just too much work for her and daughter Michelle. Thelma really likes her new place, which is nearer to most of her friends, and she can play bridge as much as she wants. Everything is close by, and she's keeping very active. Good for her. Life goes on.

### **DOWN MEMORY LANE**

We should always count our blessings in terms of our club's flying site situation. T'was not always thus. Reflection is always called for lest we fail to appreciate our good fortune.

Such was the case when I read a nice blurb in the AJC on our area's annual, dressy soiree for the horse set, the Atlanta Steeplechase. Club members from the 1980s will recall when we flew on the very same plot of lovely greenery east of Rome when it was part of the estate of a Saudi prince. The site wasn't that bad, as long as you stayed within the treeline that bordered a large horseshoe bend of the Etowah River. As we do now, we benefited from the inclination of a real fan of aviation. In this case, the prince happened to be the commander of the Saudi Air Force's helicopter fleet. We met the guy several times, and he was always good to us and thought our models were cool.

Well, we lost the field when the prince sold it to a well-heeled family who happened to be committed equestrians, and the rest is history. Since then, the owners tidied up and developed the property in a very big way, and in short order, the steeplechase was moved there. As a result, our area's horse set have the use of a fine facility that draws thousands every year. I went once several years ago and

marveled then at the changes from its hardscrabble state when we flew there. It really took me back. To reminisce, click thusly <[atlantasteplechase.org](http://atlantasteplechase.org)>.

### THIS JUST IN

Frank Perkins was kind enough to forward the following plan of his Sidewinder catapult glider. It's quite an interesting design and a great flier. The plan deserves a good look because it's chock full of Frank's homemade electronic gadgetry. He's been flying variants of the design for the past few years, and everything works. (Eagle-eyed readers will note the drawing sets up for righties, while his pictured model is for lefties like his own baddself.) Enjoy.

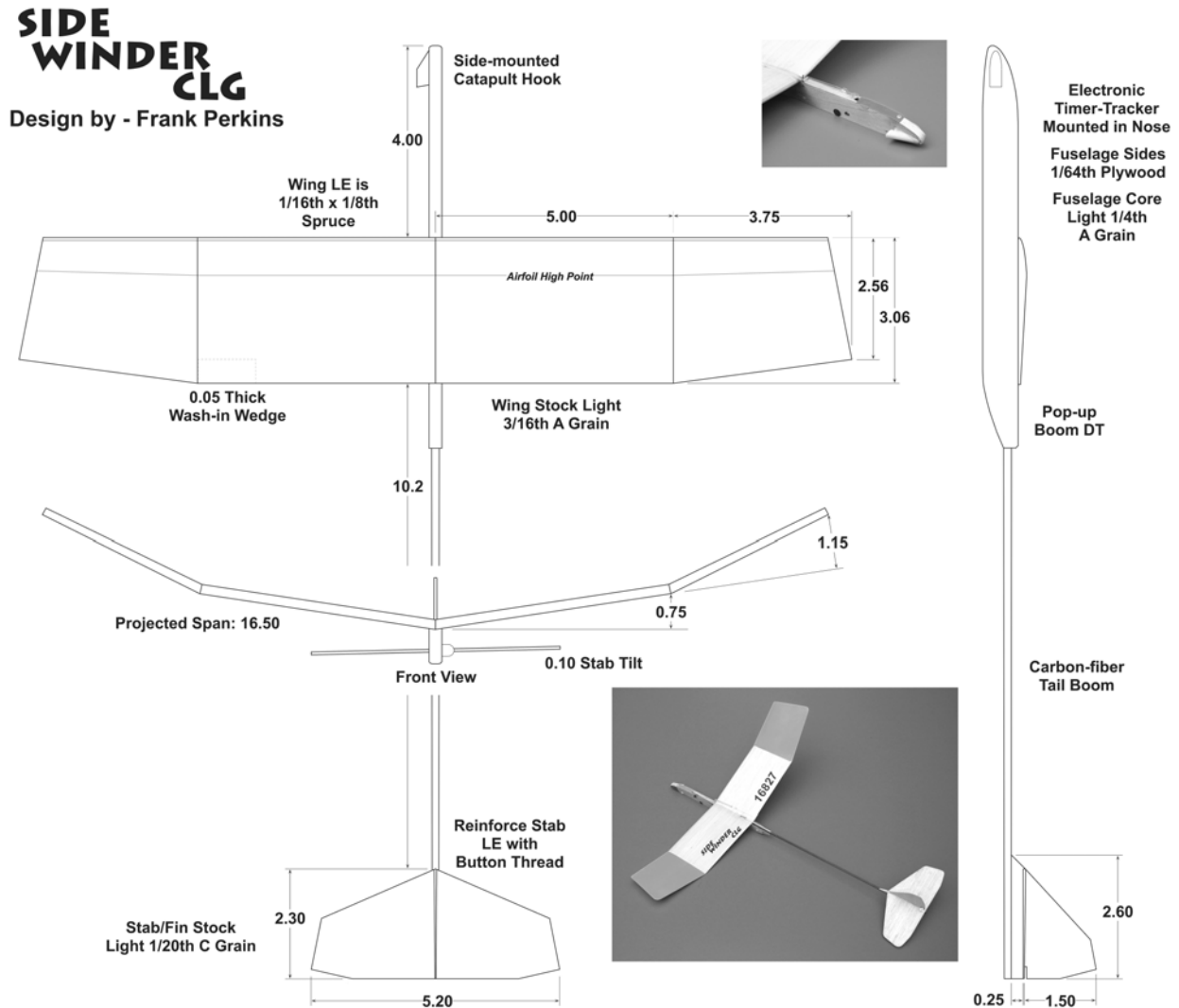

### GREAT MINDS THINK ALIKE

Karl Hube recently sent me two blurbs about cool stuff he spotted at two very popular modeling haunts, Harbor Freight and Michaels. His reportage on same follows. As fate would have it, I'm working in Nashville, and where I eat lunch has a Harbor Freight behind it. Who can resist the occasional stroll? Not me, that's for sure. A recent find by me follows, too.



Quoting Karl, “These small clamps (stock # 62242) were featured in a recent Harbor Freight advertisement in our local Sunday paper. They regularly are listed as being priced at \$3.99 at retail, but they seem to be perpetually on sale for \$1.99. When I stopped by an area Harbor Freight retail store, I picked up four and have found them very useful. The slide bar is six inches long which allows the jaws to open to nominally four inches. The jaws are soft enough to allow clamping model parts without marring them. When buying at the store, slide the moving jaw to be sure the action is smooth as some seem to be a bit rough. A good value at \$1.99.

“A model flyer in England recently e-mailed me about Stretch Magic Thread. It is an elastic thread that is used in making bead bracelets. At first glance, it looks like monofilament, but it is very elastic. It is manufactured in several sizes ranging from 0.5 mm to 1.0mm in diameter. I could only find 0.5 mm and 1.0 mm on the displays at Michael’s in Canton. The 0.5 mm shows promise as the elastic power to drive the homemade viscous timers on my catapult gliders. The 1.0 mm seems too powerful for most things we attempt to do. There are 0.7 mm and 0.8 mm which are in circulation, and they deserve some attention, too. I find a long, soft elastic element easier to get working than a shorter, more powerful unit like a spring or taut rubber band. We’ll have to see how this material performs in our summer heat as the viscous timers speed up with increase temperatures.” Thanks, Karl.



The active Free Flight modeler makes good and frequent use of binoculars. All of us have a pair, but mine is getting long in the tooth. Also, while its wide field of vision is nice, the magnification leaves a lot to be desired in tracking flying models at great distance.

While walking off a little lunch in Nashville at the nearby Harbor Freight recently, I spied the accompanying pocket-sized pair on sell for ten dollars, American. (OK, pocket-sized if you’re wearing cargo shorts and not your disco, party pants.) Financially, I’m back in the Middle Class these days, so I went for it. And it turned out to be a smart purchase. They’re made by Gordon (item # 92442), and the construction looks sturdy. Also, the carrying case comes with a belt strap if you’re nerdily inclined. If the Cooper’s Hawks and cell phone towers ITP are any indication, the 10X power is well suited for distant flying objects. The limited field of vision is the tradeoff, but in

our application, who cares. And at ten bucks, you can’t beat the value.



**NEXT ISSUE**

Look for something right after the June FAC contest. Expect a lot of pictures of same and a thorough pinging of the USOC in Muncie later in the summer. Hopefully, we'll have a ton of good news on the Thumbs' success at the USIC in Colorado. Last I heard, the local indoor luminaries were going.

As always I beseech the multitudes for contributions in the way of articles, plans, articles, rants and raves. Don't make me work too hard. Ciao, y'all!

**2015 TTOMA MEMBERSHIP FORM**

Name \_\_\_\_\_ AMA # \_\_\_\_\_

Address \_\_\_\_\_

State and Zip Code \_\_\_\_\_

Other Family Members and AMA # \_\_\_\_\_

Telephone \_\_\_\_\_ E-Mail \_\_\_\_\_

\$20.00/yr. adults, plus \$1.00/yr. for all kids and additional family members in same household. Send check, payable to TTOMA, to Karl Hube/104 Smith Forest Ln./ Alpharetta, GA 30004/770-886-0104.

<b>NFFS MEMBERSHIP &amp; RENEWAL APPLICATION</b>	<p>Mail to: NFFS Membership Office P.O. Box 74 Grosse Ile, MI 48138 USA</p> <p>Dues include a mandatory \$0.50 per year for NFFS membership.</p> <p>Make checks payable in U.S. dollars to: National Free Flight Society</p> <p><b>U.S. memberships (Age 19 &amp; over)</b>  <input type="checkbox"/> 2 years \$58.00 (\$18.00 Youth)  <input type="checkbox"/> 1 year \$30.00 (\$10.00 Youth)</p> <p>Youth: Age 18 &amp; under as of July 1 of the current year</p> <p><input type="checkbox"/> Check here if you desire <i>Digest</i> delivery via email. This saves valuable funds on printing/mailing, and you get your <i>Digest</i> about 3 weeks sooner. As a bonus, the electronic version contains exclusive content in each issue.</p> <p><b>All Non-US Residents</b>  <input type="checkbox"/> 2 years \$58.00  <input type="checkbox"/> 1 year \$30.00</p> <p>NOTE: Current international members will continue to receive printed <i>Digest</i> until membership runs out. Effective with May/June 2012 issues, all new/renewal international memberships will receive <i>Digest</i> electronically.</p> <p><b>Life Membership</b>                  U.S. Residents <input type="checkbox"/> \$500.00                  Non-U.S. Residents <input type="checkbox"/> \$550.00</p> <p><b>First-Time or Lapsed (more than 1 year) Domestic Members</b>  <input type="checkbox"/> 2 Years for \$29 <input type="checkbox"/> 2 Years Youth for \$9 <input type="checkbox"/> International \$37.50                  Offer expires very soon...take advantage before it's gone.</p> <p><b>★ NFFS Foundation Donation ★</b>  <input type="checkbox"/> Silver \$75 <input type="checkbox"/> Gold \$125 <input type="checkbox"/> Platinum \$250 or more \$_____</p> <p>To help reduce expenses maintaining NFFS records, PLEASE renew for at least two years. Thank you!</p> <p>Check appropriate boxes below:                  New Member <input type="checkbox"/> Renewal <input type="checkbox"/> Address Change <input type="checkbox"/> Donation <input type="checkbox"/></p> <p>Amount: \$_____ Current expiration date: Mo.-Yr. _____</p> <p><b>PLEASE PRINT VERY CLEARLY</b></p> <p>Name: _____</p> <p>Address: _____ AMA#: _____</p> <p>City, State: _____ Zip: _____</p> <p>Telephone: _____</p> <p>Email Address: _____</p> <p>Send all renewals, address changes, applications, and membership questions to the Membership Office, email: &lt;martinr362@aol.com&gt;</p>
Please go to <a href="http://www.freeflight.org">www.freeflight.org</a> for credit card renewals.	



**Contest report**  
**TTOMA Indoor Contest**  
**St. Lukes**  
**Mar. 7, 2015**

Official flights were made in LPP, Ministick, No-cal, and Helicopter.

Here are the complete scores:

**Limited Penny Plane**

Karl Hube 4:15, 3:02, 4:36, 3:59, 4:25

**Wright Stuff (unofficial)**

Bill Gowen 3:30, 2:31, 3:23, 3:17

**Ministick**

Nick Ray 6:45

**No-cal**

Richard Schneider 1:17, 1:25, 1:19 (4:01 total)

(Boeing XP-9)

Karl Hube 1:37, 1:13, 1:36 (4:26 total)

(Chambermaid)

**Helicopter**

Karl Hube 2:14, 2:31, 3:14, 2:48

**April Fools Contest Results**

“The weatherman said the wind would blow and this time he was right!! When I arrived at the field at about 8:45 am, there was just a slight drift as observed with a couple of catapult flights. Frank Perkins came in from Tuscaloosa, and we checked two spots as launch places before selecting a spot well down the field beyond the hanger and well away from the office area. In those few minutes, the tempo of the wind began to pick up.

“As our Australian friends say in their contest reports, we had a modest “roll-up” for the competition.



Four members faced the gale to attempt some action. A couple of guys were out of town and one man phoned in sick. (Hint: They don't call him “Barf” for nothing!) Dana Russell, David Mills, Frank Perkins and I tried a couple of events and struggled with the wind all day. This was one of those cases where a 30 second CLG flight would give you a long retrieve walk! The upwind walk on retrieval was tough on man and model.

“Dana was out with a couple of new models that gave him some trouble including motors that broke when they were stretched even before the winder started turning! A good effort and some points learned on the first day out for 2015. Mills and I

collectively demolished three CLG's. Frank escaped with everything intact and accounted for. Here are the results for the day, submitted by: Karl Hube, CD:"

<u>Catapult Glider (60-sec max)</u>							<u>Total</u>
Frank Perkins	7	60	44	32	45	5	149
Karl Hube	33	34	34	34	30	15	102

<u>Old Goat Smackdown (90-sec max)</u>	
David Mills	65

## Peach State Indoor Champs Report

We had another great time this year. Tim Lavender brought ten kids and a couple of adults. A handful of Thumbs rounded out the crowd. Attendance may've been hurt a tad with the date's being right before Easter, but maybe not. Regardless, the thirteen fliers flew up a storm all day. Young Jelly Poe set a junior A-6 national, category I record. Also, young Mu Mu was a standout in Bostonian.

We'll do it again next year. The results and photos follow, David Mills, CD:

### F1M

Josh Finn 10:12, 10:37  
 Bill Gowen 6:49, 5:43

### 35 CM

Josh Finn 18:03, 19:01

### Limited Pennyplane

Josh Finn 6:22  
 Karl Hube 5:47

### Ministick

Nick Ray 8:03

### Helicopter

Karl Hube 2:35

### Phantom Flash

Ta La Htoo 162  
 Damariz Vargas 142  
 Mu Mu 112  
 Jerry Pawe 107

### A-6

Bill Gowen 7:31

### Bostonian Jr.

Mu Mu 3:01  
 Damariz Vargas 1:54  
 Ta Chay 1:19  
 Ta La Htoo 0:40  
 Jelly Pawe 0:35

### No Cal Scale

Karl Hube Chambermaid 321  
 Robert Schott Stallion 214  
 Mu Mu Fokker F.11 182  
 Ta La Htoo Fokker F.11 143  
 Jelly Pawe Fokker F.11 103  
 Ta Chay Fokker F.11 85  
 Damariz Vargas Stallion 7  
 Nay Reya Fokker F.11 7

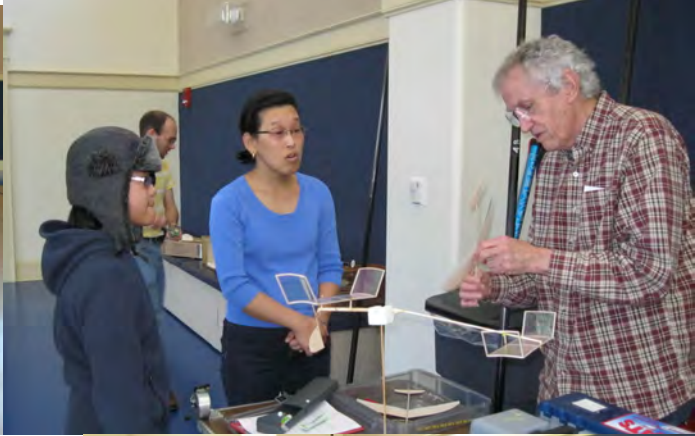

## **April Meeting Minutes**

The April 26<sup>th</sup> TTOMA meeting was called to order by Secretary Karl Hube at 12:00 noon at the North Georgia Turf Farm. Four members were present, and because of the small group, the meeting was held in a simple discussion format.

### Treasurer's Report

Karl Hube reported that the current club balance was \$X,XXX.XX. The only outstanding debt is the 2015 sanction fees to be paid to Dohrman Crawford. Although Dohrman has not invoiced the club for the fees, it is expected that the total charge will be \$400.00. All other fees have been paid including the club 2015 AMA Charter and site insurance for the sod farm and St Luke's indoor flying venue. The report was accepted without discussion.

### Secretary's Report

The minutes from the last 2014 TTOMA meeting (October) were read. No discussion followed and the minutes were accepted.

### Old Business

One point about club-supported FAC competition was discussed. Jim Altenbern and Gary Morton have looked into the idea of converting the June contest into a full two-day FAC oriented competition. They finally came to the conclusion that there just are not enough FAC flyers within a reasonable driving distance to justify such an undertaking. This point will be discussed further with more people involved, but it may take an ongoing marketing effort, plus more experience on our part at running a bigger contest to make a two-day event possible.

### New Business

David Mills reported success with the Peach State Indoor Championships flown at St Luke's. Rev. Tim Lavender from Smyrna, Tennessee brought ten young flyers to compete. Interestingly, many of the young folks were from an apparently sizeable Thai community in the Smyrna area. They were bright, energetic, and happy kids who flew A LOT of planes. One of the boys set a new Junior Record time in A-6. Well done to the entire group.

Frank Perkins reported that the TTOMA competition schedule is posted on both the Hip Pocket Aerodynamics website, as well as the TTOMA Facebook site.

Frank hopes to go to Texas for a Cloud Climber competition on the May 2-3 weekend. While there, he wants to determine if any FAC flyers there would be interested in coming to Whitesburg for an FAC gathering.

There being no further discussion, the meeting was adjourned at 12:23 pm. Minutes respectively submitted by Karl Hube, Secretary.