



The THUMB PRINT
Thermal Thumbers Of Metro Atlanta

www.thermalthumbers.com
David Mills Editor
 (404) 509-4209
 davidmillsatl@gmail.com





July-August, 2015

HEADS UP

Welcome to the July issue. Herein you'll find a full report on the Thumbs' trip to Muncie for the USOC, but let's just say at this point that our presence was felt, and we won our share of fame and glory. Also, a report follows on one of the most dramatic days we've ever had at St. Lukes. Long story short, Kang Lee set a F1D Cat. 1 world record and proved once again that St. Lukes is where indoor records go to die. Filling out the issue, a few contests reports and other items of interest are thrown in for your information. Glue some sticks together and show up somewhere with a model airplane! Time for me to get out of the way. Ciao, y'all!

THINGS TO SEE, PLACES TO BE, PEOPLE TO SEE

We've only the last of the summer and entire fall flying season left, so don't neglect what opportunities that are left. You can't say we don't provide them.

Sept. 5. Outdoor. N GA Turf Farm. David barfield CD
 Sept 19. Indoor. St Lukes. Bill Gowen CD
 October 4. Outdoor. N GA Turf Farm. David Mills CD
 October 10. Indoor. St Lukes. Nick Ray CD
 Oct. 17-18. Raeford Free Flight Contest. Raeford, NC.
 November 8. Outdoor. N GA Turf Farm. Turkey Shoot. Gary Baughman CD
 November 21. Indoor. St Lukes. Bill Gowen CD
 December 12. Indoor. St Lukes. Nick Ray CD
 Dec. 31-Jan. 2. KOI. Palm Bay, FL.
 Jan. 30. Annual Banquet. Petit Auberge. Dohrman Crawford

THUMBS IN PRINT

Once again walking a well-worn path, Bill Gowen's nationally dominating Limited Pennyplane, *Carbon Penny*, has been selected as a 2015 NFFS Sympo Model of the Year. He's no stranger to such accolades, its being the fourth such in six years. Well done, Bill!

And we shouldn't neglect the contribution young Robert Marier made to the 2015 sympo. He served as chairman of the MOY committee, herding the cats as required and doing an excellent job. It turns out that he's a capable writer, which will serve him well in college and beyond. You know what they call an engineer that can write? A manager!

Other Thumbs made contributions to the Sympo. Chris Stoddart coauthored a paper with Ralph Ray with a creative discussion of downthrust, taking issue with the old adage that downthrust is only a necessary evil and to be minimized to the greatest extent possible. A wide ranging discussion is put

forth whereby the optimum amount of same can sometimes be found well beyond what's considered acceptable. It should affect how we trim the climb of all our models, henceforth.

Josh Finn authors a paper where he discusses some of the factors behind the recent upsurge in F1D performance. He dissects the design characteristics of several of the best performing F1Ds in the world and holds forth of the pertinent factors thereof, as he sees it. Readers beware: there is math involved! However, much of it is concerned with tail volume and stability margin, and I was able to follow it in broad strokes. (Parts did give me a headache, though!)

Several Thumbs and friends served as Sympo patrons, too. Many thanks to Bill Brown, Dohrman Crawford, Geoffrey Grosgruth, Dean McGinnes, Frank Perkins, Graham Selick, Chris Stoddart, Jim Conery, Rolf Svensson, Jimmy Jordan and Paul Sanders.

THUMBS ON THE MARCH: MUNCIE NATS

We had a good group of TTOMA members and friends in Muncie for the USOC. Your editor, Dohrman Crawford, Frank Perkins, Scott Lapraik, Graham Selick and grandson Hayden, Big Jim Lewis, Ed Hardin, Jim Jennings Sr. and Jr., Claiborne Wilson and Robert and Tom Marier, all came to fly, and fly we did. Two days offered pleasantly calm conditions, two were plenty OK, and only one was too breezy. Heat wasn't really a problem, and a few nights actually got quite chilly, allowing leaden and welcomed slumber for the campers. There were no storms worth mentioning. The widely proclaimed Great Lakes of Muncie had dried up for the most part, and only two ponds of any consequence remained for Free Flight week. It took a while for the food dude to get rolling, but once he did, he provided a good substitute for the Hot Dog Man. The annual cookout and raffle and the evening banquet were outstanding. (Get Dohrman get him to tell you how he missed the banquet!)

Manly toeing the line, our efforts weren't wasted. Your editor's contribution was meager, but everyone else exported more than their fair share of mahogany across the mighty Ohio. The high finishes follow. Not a bad week's work, considering all the fun we had.

David: 3rd in Dime Scale

Dohrman: 5th in E-36

Frank: 5th in Small Mulvihill, 5th in OT Catapult Glider, 5th in Catapult Glider

Scott: 5th in A/B Classis Gas, 6th in A NosGas, 7th in B NosGas, 4th (t) Electric A

Graham: 6th in Electric B, 4th (t) Electric A

Hayden: 2nd in Electric B Jr. and E-36 Jr., 1st in 1/2A Classic Gas, 5th in Electric A, 4th in 1/4A NosGas

Big Jim: 2nd in OT HLG

Ed: 3rd in Mulvihill, 2nd in Small NosRub

Jim, Sr.: 5th in Moffett

Jim, Jr.: 7th in Electric B, 2nd in E-36

Claiborne: 3rd in OT HLG, 1st in Sr. Mulvihill, 1st in P-30 Sr.

Robert: 1st in Small Mulvihill, 2nd in Moffett, 4th in Small NosRub, 4th in Dawn Unlimited





THUMBS AT THE WORKBENCH

The Thumbs continue to spend useful time at the workbench. Josh Finn was kind enough to forward the following photo (left) of his new *Farthing Lightweight*, another of the intriguing British Lightweights. Mick Farthing was central to the Lightweight movement, being a prolific designer/*raconteur* of same at the time. However, his *Lightweight* is seldom seen this side of the pond. Freshly minted, Josh's *Lightweight* promises good performance, and it's a real cutie. (And for those still asleep at the switchboard, it and its peers also qualify for the SAM OT Rubber Fuselage category.)

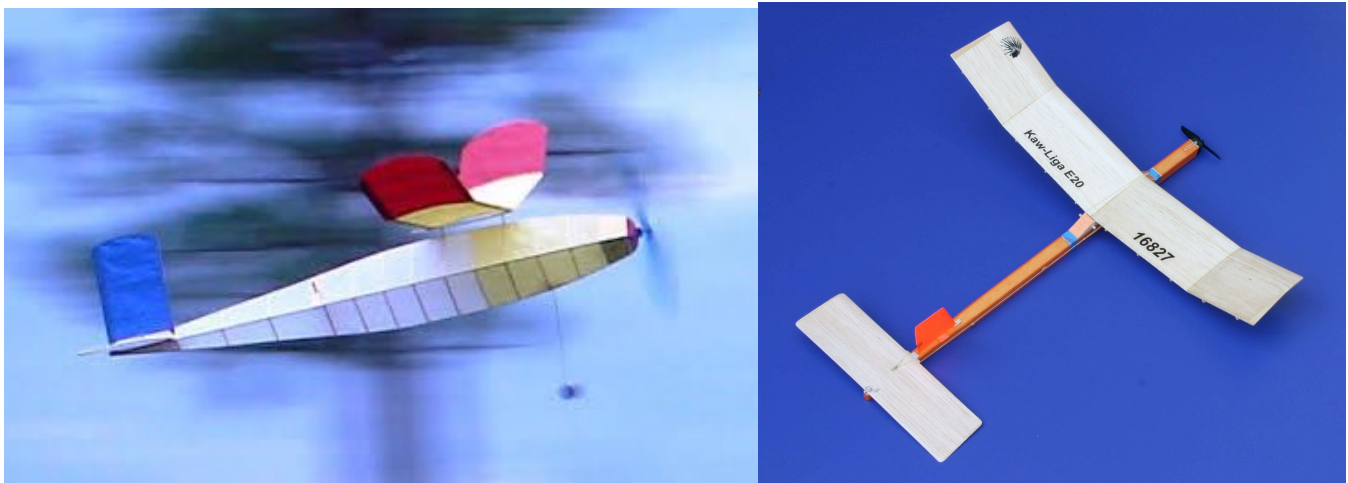

Frank Perkins passed along a photo (right) of his latest E-20 project, the enigmatically named *Kaw-Liga*. It's a real cutie and somewhat unique in incorporating all-wood construction and a Jedelsky airfoil, no less. It should fly just fine; all of his models do.

MORE LIGHTWEIGHT MATERIAL

Receipt of Josh's message on the *Farthing Lightweight* snapped me back to attention regarding the recent publication of *Flying North*, the superb biography of Jack North, the great British Free Flight luminary, by Beales and Dilly. The book also contains a ton of plans of North's designs, spanning decades. Two of his best Lightweights are among the many tasty offerings, and they follow for your erudition. The *Upstairs Maid* (1947) looks like a winner, and the *Diamond Lightweight* (1949) comes highly recommended. The book is a fine read and a good value, and I recommend it highly. It's available at numerous places.

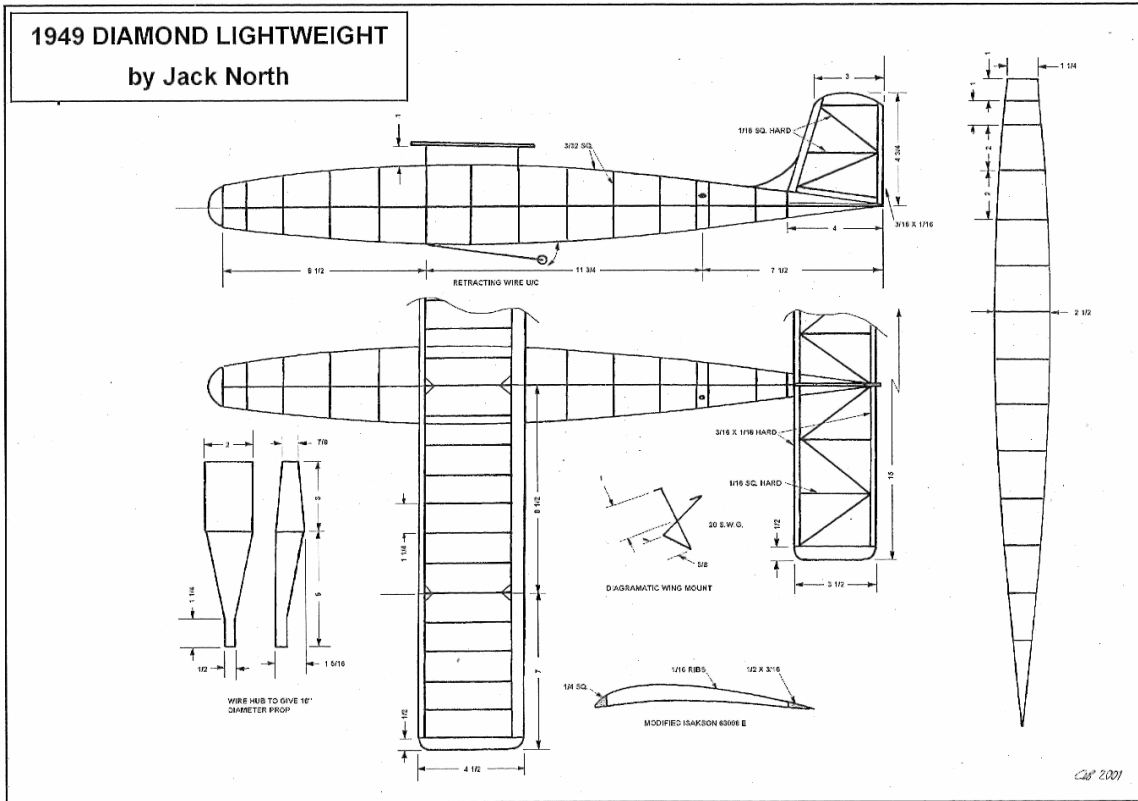
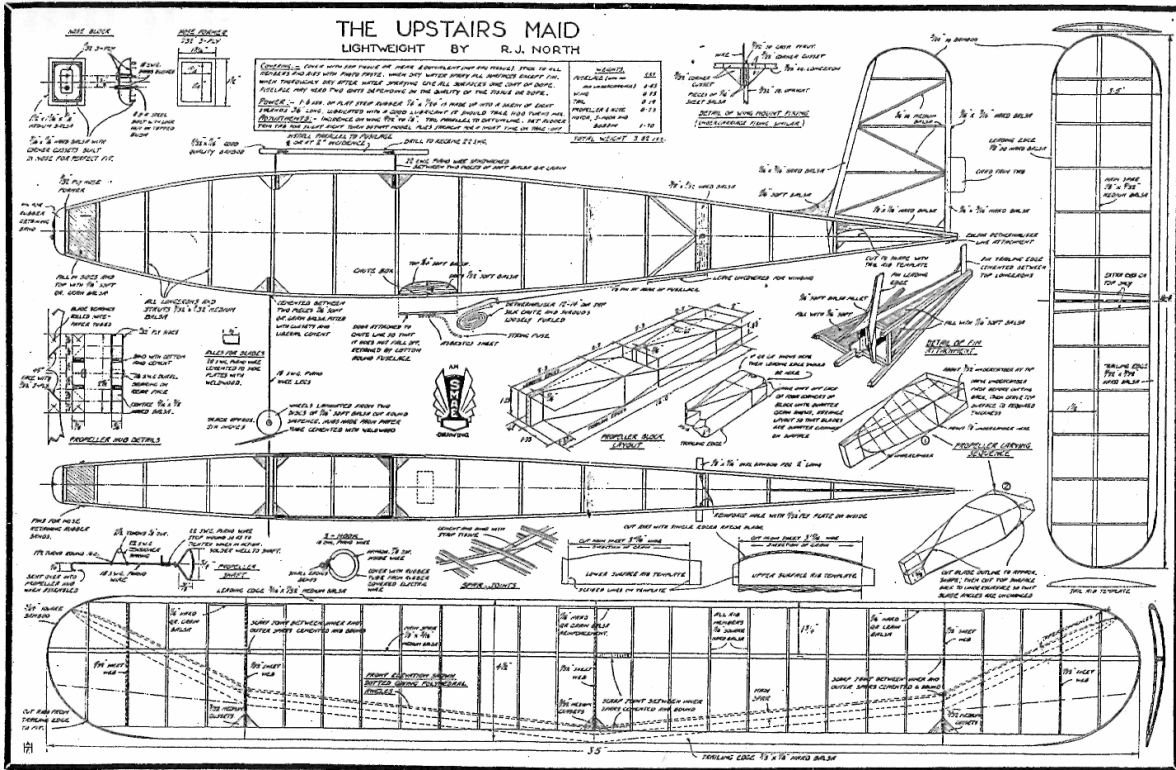

YOU REALLY THINK WE'RE NUTS?

The Free Flight community does a little navel gazing on occasion, and we sometimes rank ourselves a bit *outré* among the other hobbyists of this world. This writer presents the following material as a useful perspective and as evidence to the contrary.

I follow many types of modeling, and Atlanta is a good town for it, providing venues and occasions a-plenty. Many years ago at a plastic modeling tradeshow, the world of the 1/6th scale armor enthusiast was brought to my attention. The following photos can speak for themselves. (You think your workshop is a crowded mess!)

The internet offers a wealth of eyecandy on this bunch, and panzerwerk.com has the best links. armortek.co.uk is a must see. Enjoy!



MAKING A LIST, CHECKING IT TWICE

It about time to get serious, if the club's high point tourney means anything to you. Most of the local contest calendar is behind us, and therefore, fewer opportunities before us. The following tally takes us through August. And it's crowded at the top and a house divided! A little more pep at the back end, y'all, could make a real difference. Competition culls the weak, inspires the ambitious and gets us out of the house on the weekends!

Josh Finn 26
Hope Finn 24
Karl Hube 21
David Mills 20
Frank Perkins 19
Gary Morton 12
Jim Altenbern 10
Nick Ray 9

Bill Gowen 8
Dohrman 7
Graham Selick 5
Gary Baughman 4
David Barfield 3
Richard Schneider 3
Joe Ryan 1

NEXT ISSUE

Look for something in October. We'll have the next few indoor and outdoor contest reports, as well as the Turkey Shoot flyer. Make your plans to attend. We'll also carry the club high point results and a closing nag as to making most of your opportunities as to same. One nag before I go: the 2015 NFFS

Symposium is now for sale and yours can be bought for 35 dollars, American, plus postage. For yours, contact Bob Stalick at: freeflyer@aol.com.

Once again, I beseech the multitudes to forward any articles, photos, plans, rants and raves to these humble pages. Don't make me work too hard! Ciao, y'all!

July Indoor Contest Report

St Luke's witnessed some very good flying Saturday. Conditions were excellent, with little drift. Only a few fliers showed up. We ought to take advantage of this resource, and all make an effort to fly some indoor models. Respectfully submitted by Dohrman Crawford, cub reporter. Here are the times:

F1D (1/4 motors)

Joshua Finn 6:15

Nick Ray 6:10

Hope Finn 5:22

Ministick

Nick Ray 6:45

A-6

Hope Finn 3:50

Joshua Finn 3:38

Limited Pennyplane

Bill Gowen 7:47

Contest Report Pop Purdy's

August 8, 2015

Omitting temperature and humidity, Sunday was the best flying weather we have had at the Sod Farm in quite some time. Winds up until noon were light and variable and then became more variable than light, but presented no drift problems. Thermals were sporadic and light despite the sunshine and cumulus clouds. Six people registered; however, only four posted official flights.

Flying was terminated at 3:00 pm to avoid having everyone receive a free shower and car wash with genuine Chattahoochee River Elixir, courtesy of the juxtaposition of the two irrigation booms.

Scores are as follows, CD Graham Selick, reporting:

CLG

Frank Perkins Sidewinder **173**

Jim Altenbern Straight Up 132

E-20

Gary Morton First Try **164**

TLG/HLG

Jim Altenbern Meerkat 29 **118**

E-36

Graham Selick Accorte III **430**

BRS/Old Goat Smackdown

Graham Selick **243**

Jim Altenbern 163

Dime Scale

Gary Morton PT-19 **106**

Contest report
TTOMA Indoor Contest
St. Lukes
Aug. 15, 2015

At the Aug. 15 contest we were honored with the presence of a number of out-of-town luminaries from the world of competitive indoor flying. The main event of the day was World Record attempts by Kang Lee, current World Champion, at setting a new F1D Cat 1 World Record. Kang flew 5 official record attempts during a long, hot day and evening. The record was set higher on each of the first, second, fourth and fifth flights with the eventual high mark being 22:50.

Also in attendance were Bud Layne and Dudley Parker from Kentucky who flew in (literally) to fly their LPP's. Some very nice times were turned which forced me to get out my LPP to save face.

Leo Pilachowski and wife Katy drove down from Indiana. Leo flew his F1L's all day but didn't record any times.

The party was rounded out with locals Josh and Hope Finn (and Little Finn) and Nick Ray.

Here are the complete scores - or at least the ones recorded:

F1D

Joshua Finn	19:49, 19:57, 20:27
Kang Lee	21:20, 21:53, 21:35, 22:38, 22:50

Limited Penny Plane

Bud Layne	7:32, 7:26, 5:57
Dudley Parker	7:06, 7:06, 6:59
Bill Gowen	7:38, 7:30, 8:24

A6

Hope Finn	1:56
-----------	------

Phantom Flash

Hope Finn	33
-----------	----





July Meeting Minutes

The July TTOMA meeting was called to order by President David Barfield at 12:30 pm at the N GA Turf Farm with eight members present.

Treasurer's Report

Karl Hube reported that the current club balance was \$X,XXX.XX, and no debts are outstanding. David Mills made a motion to accept the minutes, and Frank Perkins gave a second. The report was accepted without additions or corrections.

Secretary's Report

The minutes from the last meeting (June, 2015) were read. David Mills made a motion to accept the report, and Frank Perkins made gave a second. No discussion followed, and the minutes were accepted as presented.

Old Business

David Mills reported that members going to Nationals in Muncie, Indiana will be disappointed to learn that the traditional hot dog vendor will not be there this year! Seems he has another gig that conflicts with the competition schedule. Pack your own munchies for the trip.

Jim Altenbern reviewed some points that may help us have a better developed two-day contest in June of each year. He believes that having restroom facilities on site will be important. Toward that objective, Jim will explore our options to meet this need. Jim also brought up the open issue of changing the Model of the Year (MOY) and Event of the Year (EOY) for the future. Since the EOY is not supported very well, the suggestion is to drop the EOY and focus on the MOY. One objection to such action is that we have a good trophy in use for the EOY. The new open question is how the EOY

trophy could be repurposed? Regarding the MOY, it was stated that we need to select models that can serve in multiple events and be simple to build and repair.

Another subject Jim addressed was the old matter of purchasing Hall of Fame bricks for the walkway at the AMA headquarters. The bricks are priced at \$100 each, unless bought in lots of ten which would trigger a discount. This matter was left open as the idea of spending \$900 to \$1,000 for the project did not generate any significant discussion.

New Business

Karl Hube gave a brief evaluation of two vendors...Volare Products (aka, Shorty's Basement) and McMaster-Carr. Volare Products had a good selection of propellers, bearings, and a new needed winder, and all were delivered quickly at a reasonable postage cost. In the case of McMaster-Carr, the order contained a mix of drill bits, 2 x 56 brass machine screws, a tap for the machine screws, a pin vise, a small tap wrench and some 6062 aluminum sheets. The order was placed late on a Monday night and the order arrived the next afternoon! The shipment came from the Mableton, Georgia warehouse to my home in Cherokee county, and the UPS charge was \$5.25. Clearly, I couldn't drive to Mableton to pick up the order for that cost. By the way, the order was complete, too.

The question was raised as to why we sanction all our outdoor contests? We assume the sanction is required for keeping our insurance in force. Jim will look into this point. Indoor contests are sanctioned for the same reason, plus indoor events also produce official AMA records.

There being no further business, Graham Selick made a motion to adjourn, and all attendees voted for the motion. Minutes respectfully submitted by Karl Hube, Secretary.

August Meeting Minutes

The August, 2015 TTOMA meeting was called to order by President David Barfield at 12:35 pm at the N GA Turf Farm with five members present.

Treasurer's Report

The club treasurer, Karl Hube, was not present at the meeting. Therefore, no update was presented.

Secretary's Report

The club secretary, Karl Hube, was not present at the meeting. Therefore, no minutes were read.

Old Business

Jim Altenbern presented the reasons for obtaining a sanction for every meet. They included having additional insurance for flying sites other than the one club site mentioned in the club charter, listing the meet in the AMA Magazine and contest directors getting AMA dues credit for the meets they run.

Jim Altenbern discussed having a Hall of Fame for the TTOMA club. Members past and present which are voted in to this Hall of Fame will have commemorative bricks with their names on them placed at the AMA's Walk of Fame. There was some discussion about how many bricks to buy, where they would be placed and their cost. There was no further discussion on the issue, and it was tabled.

Gary Morton presented the progress on the two 2-day meets for next year. We discussed which events to have and how to limit the flights for our small field. Gary will send a preliminary list of events and prizes to Jim Altenbern which will be discussed at the September contest.

New Business



No new business was presented.

With no further discussion, the August meeting was adjourned at 1:00 pm. Respectfully submitted by Jim Altenbern, Vice President.

Partial 2015 TTOMA Membership Form

Name _____ AMA # _____
Address _____
State and Zip Code _____
Other Family Members and AMA # _____
Telephone _____ E-Mail _____

For remainder of year only: \$10.00/yr. adults, plus \$1.00/yr. for all juniors and additional family members in same household. Send check, payable to TTOMA, to Karl Hube/104 Smith Forest Ln./Alpharetta, GA 30004/770-886-0104.

IMPORTANT RENEWAL INFORMATION				
To continue receiving NFFS Digest without interruption, your dues should reach the NFFS Membership Office at least two (2) months before your current expiration date. For example, if your Digest mailing label says your month of expiration is August, NFFS should receive your payment by June. Do not wait for a reminder from NFFS. You will be late and miss an issue.				
NFFS MEMBERSHIP & RENEWAL APPLICATION				
Mail to: NFFS Membership Office P.O. Box 74 Grosse Ile, MI 48138 USA	Make checks payable in U.S. dollars to: National Free Flight Society			
Dues include a mandatory \$0.50 per year for NFFS membership.				
U.S. memberships (Age 19 & over)	<input type="checkbox"/> 2 years \$58.00 (\$18.00 Youth) <input type="checkbox"/> 1 year \$30.00 (\$10.00 Youth)			
Youth: Age 18 & under as of July 1 of the current year				
<input type="checkbox"/> Check here if you desire Digest delivery via email. This saves valuable funds on printing/ mailing, and you get your Digest about 3 weeks sooner. As a bonus, the electronic version contains exclusive content in each issue.				
All Non-US Residents	<input type="checkbox"/> 2 years \$58.00 <input type="checkbox"/> 1 year \$30.00			
NOTE: Current international members will continue to receive printed Digest until membership runs out. Effective with May/June 2012 issues, all new/renewal international memberships will receive Digest electronically.				
Life Membership	U.S. Residents <input type="checkbox"/> \$500.00 Non-U.S. Residents <input type="checkbox"/> \$550.00			
First-Time or Lapsed (more than 1 year) Domestic Members				
<input type="checkbox"/> 2 Years for \$29 <input type="checkbox"/> 2 Years Youth for \$9 <input type="checkbox"/> International \$37.50 Offer expires very soon...take advantage before it's gone.				
★ NFFS Foundation Donation ★				
<input type="checkbox"/> Silver \$75 <input type="checkbox"/> Gold \$125 <input type="checkbox"/> Platinum \$250 or more \$ _____				
To help reduce expenses maintaining NFFS records, PLEASE renew for at least two years. Thank you!				
Check appropriate boxes below:				
New Member <input type="checkbox"/> Renewal <input type="checkbox"/> Address Change <input type="checkbox"/> Donation <input type="checkbox"/>				
Amount: \$ _____ Current expiration date: Mo.-Yr. _____				
PLEASE PRINT VERY CLEARLY				
Name: _____	<table border="1"><tr><td>M</td><td>D</td><td>Y</td></tr></table>	M	D	Y
M	D	Y		
Address: _____ AMA#: _____				
City, State: _____ Zip: _____				
Telephone: _____				
Email Address: _____				
Send all renewals, address changes, applications, and membership questions to the Membership Office, email: <martinr362@aol.com>				
Please go to www.freeflight.org for credit card renewals.  				

Georgia State Indoor Records

	Event	Ceiling Category	Record Type	Endurance	Date	Name	Location	National Record?
FAI Events	F1D (1.2 g)	Cat I	Single Flight	28:18	5/10/2014	Ray, Nick	St. Luke's	yes
		Cat II	Single Flight	15:10	4/14/2007	Ray, Nick	North Cobb	-
	F1D (1.4 g)	Cat I	Single Flight	19:27	7/19/2014	Finn, Joshua	St. Luke's	-
		Cat II	Single Flight	19:22	1/3/2015	Finn, Joshua	St. Luke's	yes
	F1L	Cat I	Single Flight	14:20	8/16/2014	Finn, Joshua	St. Luke's	-
		Cat II	Single Flight	13:04	1/20/2007	Gowen, Bill	North Cobb	-
	F1M	Cat I	Single Flight	15:21	3/15/2014	Gowen, Bill	St. Luke's	yes
		Cat II	Single Flight	10:07	4/16/2005	Gowen, Bill	-	-
	F1R/35CM	Cat I	Single Flight	21:44	8/25/2012	Finn, Joshua	St. Luke's	-
		Cat II	Single Flight	19:22	1/3/2015	Finn, Joshua	St. Luke's	yes
AMA Events	EZB	Cat I	Single Flight	21:04	12/8/2012	Lee, Yuan Kang	St. Luke's	-
		Cat II	Single Flight	12:35	5/17/2003	Gowen, Bill	-	-
	ROG Cabin	Cat I	Single Flight	-	-	-	-	-
		Cat II	Single Flight	-	-	-	-	-
	Intermediate Stick	Cat I	Single Flight	13:26	3/17/2012	Finn, Joshua	St. Luke's	-
		Cat II	Single Flight	10:56	10/21/2000	Barker, John	-	-
	HLS	Cat I	Single Flight	28:18	5/10/2014	Ray, Nick	St. Luke's	-
		Cat II	Single Flight	15:10	4/14/2007	Ray, Nick	North Cobb	-
	A-6	Cat I	Single Flight	7:53	6/15/2013	Gowen, Bill	St. Luke's	yes
		Cat II	Single Flight	5:07	3/18/2000	Lavender, Tim	-	-
	AROG	Cat I	Single Flight	-	-	-	-	-
		Cat II	Single Flight	-	-	-	-	-
	LPP	Cat I	Single Flight	10:25	4/21/2012	Gowen, Bill	St. Luke's	-
		Cat II	Single Flight	10:27	3/22/1987	Klemetsen, Howard	-	-
	OPP	Cat I	Single Flight	12:17	9/10/2005	Gowen, Bill	Chamblee	-
		Cat II	Single Flight	11:08	4/16/2005	Gowen, Bill	North Cobb	-
	Ministick	Cat I	Single Flight	9:19	7/19/2014	Finn, Joshua	St. Luke's	-
		Cat II	Single Flight	6:52	5/19/2001	Downs, Sandy	-	-
	Helicopter	Cat I	Single Flight	6:09	11/19/2011	Finn, Joshua	St. Luke's	-
		Cat II	Single Flight	1:46	10/30/1999	Perryman, George	-	-
	Ornithopter	Cat I	Single Flight	2:13	?	Singer, Len	-	-
		Cat II	Single Flight	2:34	4/22/2002	Goins, Chris	-	-
	Std CLG	Cat I	Best 2 of 9	1:35.9	1/11/2013	Gowen, Bill	St. Luke's	yes
		Cat II	Best 2 of 9	1:33.7	3/4/2006	Gowen, Bill	North Cobb	-
	Ult'd CLG	Cat I	Best 2 of 9	1:35.9	1/11/2013	Gowen, Bill	St. Luke's	yes
		Cat II	Best 2 of 9	1:24.5	3/17/2007	Gowen, Bill	North Cobb	-
	HLG	Cat I	Best 2 of 9	1:20.4	11/19/2005	Gowen, Bill	Chamblee	-
		Cat II	Best 2 of 9	1:20.1	3/4/2006	Gowen, Bill	North Cobb	-
	Bostonian	Cat I	Best 2 of 6	4:39	4/24/1999	Lavender, Tim	-	-
		Cat II	Best 2 of 6	5:35	10/21/2000	Barker, John	-	-
FAC Events	10 g FAC Embryo	Cat I	Total of 3	6:02	3/13/2004	Dixon, Brook	Chamblee	-
		Cat II	Total of 3	5:42	4/22/2000	Barker, John	North Cobb	-
	FAC Nocal	Cat I	Total of 3	8:07	2/21/1998	Perryman, George	-	-
		Cat II	Total of 3	8:44	4/14/2001	Perryman, George	-	-
	FAC Dimescale	Cat I	Total of 3	3:57	2/1/1997	Barker, John	-	-
Cat II		Total of 3	3:04	9/22/2001	Barker, John	-	-	
FAC Phantom Flash	Cat I	Total of 3	6:37	1/3/2015	Finn, Hope	St. Luke's	-	
	Cat II	Total of 3	-	-	-	-	-	
Misc. Events	SAM Phantom Flash	Cat I	Single Flight	4:25	4/5/1997	Perryman, George	-	-
		Cat II	Single Flight	3:05	4/22/1989	Perryman, George	-	-
	Hangar Rat	Cat I	Best 2 of 6	6:03	9/26/2009	Finn, Joshua	Ward Rec.	-
		Cat II	Best 2 of 6	7:51	5/18/2002	Perryman, George	-	-
	Chattahoochee Challenge	Cat I	Single Flight	3:19	12/11/1999	Perryman, George	-	-
		Cat II	Single Flight	5:44	10/30/1999	Perryman, George	-	-
	Butterfly	Cat I	Single Flight	1:54	12/7/2002	Perryman, George	-	-
		Cat II	Single Flight	2:13	4/22/2000	Brock, Wayne	-	-
	P-24	Cat I	Single Flight	-	-	-	-	-
		Cat II	Single Flight	2:00	9/1/2000	Bakay, Carl	-	-
	TSA	Cat I	Single Flight	2:00	3/13/2004	Ray, Nick	Chamblee	-
		Cat II	Single Flight	-	-	-	-	-
	Science Olympiad 8 g ROG	Cat I	Single Flight	4:00	4/25/2003	Goins, Chris	-	-
		Cat II	Single Flight	4:39	4/5/2003	Goins, Chris	-	-
	Science Olympiad 8 g 2004 "C" Division	Cat I	Single Flight	4:30	11/22/2003	Goins, Chris	-	-
Cat II		Single Flight	-	-	-	-	-	
Science Olympiad 8 g 2004 "C" Division w/ribbon drop	Cat I	Single Flight	4:42	10/25/2003	Goins, Chris	-	-	
	Cat II	Single Flight	4:59	3/27/2004	Goins, Chris	-	-	

KANG LEE + WORLD RECORD